

# Paarup Auto-Løbet

## Slutinstruktion 2

Der vil sikkert være flere steder på ruten, hvor der holder landbrugsmaskiner. Vi er jo i højsæson for høst. Hvis ruten er spærret af maskiner, biler eller lignende, så kører I bare uden om og fortsætter ruten på den anden side.

Husk også følgende fortolkning af reglerne for HRK: Man skal kun "køre udenom" en HRK, hvis der i det pågældende tilfælde er noget i køreordren, der tydeligt viser det.

Der kan være kantsten, som I synes er højere, end jeres bil skal udsættes for. Disse steder er det muligt at køre uden om og stadig overskue løbsruten.

Uanset hvad der er "nærmeste vej" skal rundkørsler altid køres i henhold til færdselsloven (mod urets retning.....).

Specialsignatur: ● Lygtepæl

▢ Bigballe

▲ Sten

### Kør pænt over alt

Køreordren skal indeholde følgende sider. Kontroller ved start, at I har fået den rigtige køreordre.

Klasse M og A: 1 - 2 - 3 - 4 - 5 - 6 - 7 - 8 - 9

Klasse B: 1 - 2 - 3 - 4 - 5 - 6 - 7

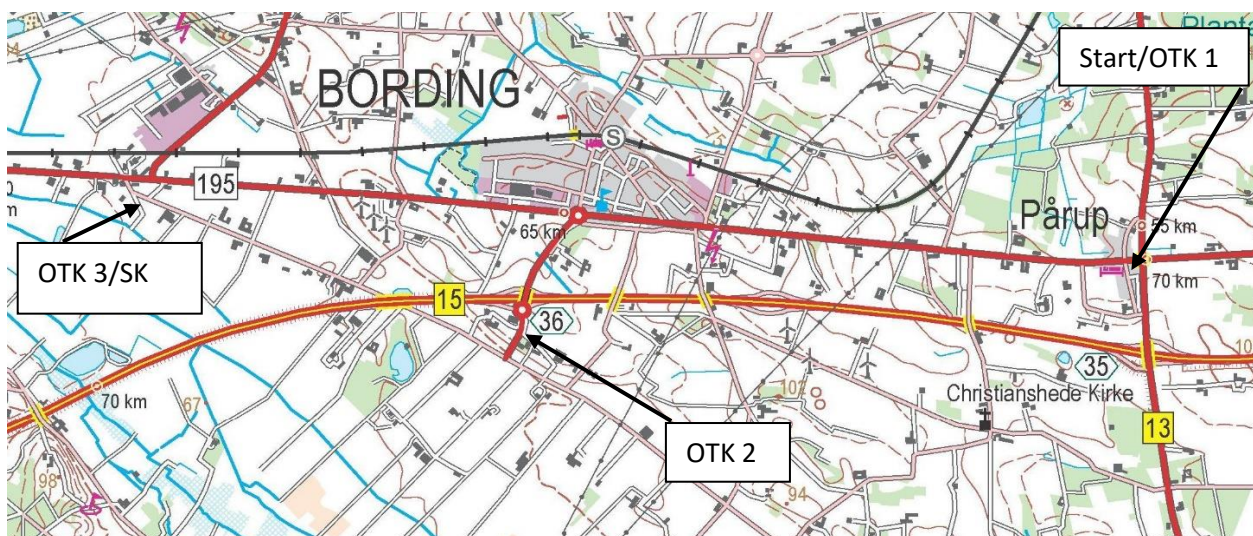

Klasse C: 1 - 2 - 3 - 4 - 5 - 6 - 7

Transportetape til samlingsstedet i IMK's klubhus udleveres ved SK.



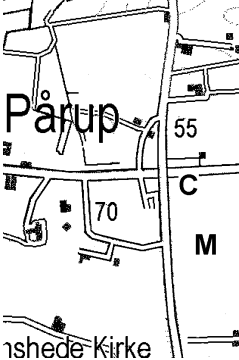
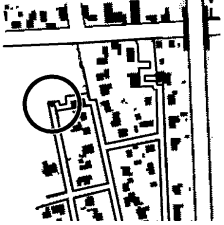
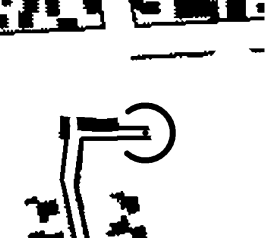
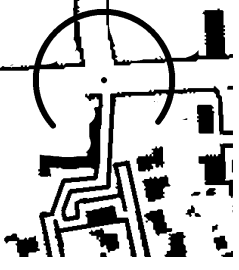
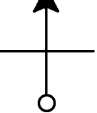

Løbsledelsen tlf. nr. er 20 97 95 51 (Jan Søndergaard)

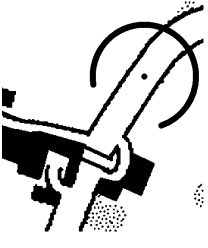
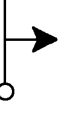
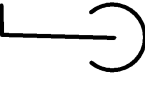
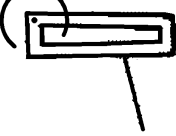

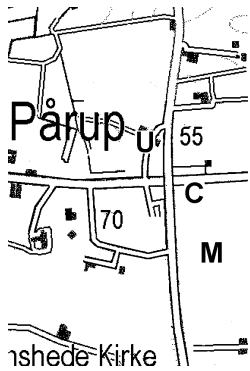
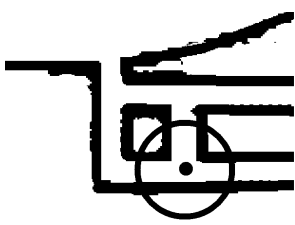
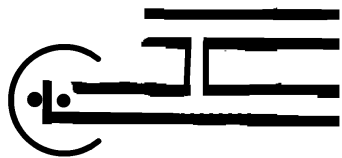
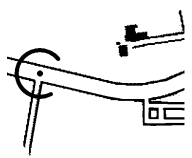
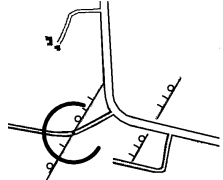
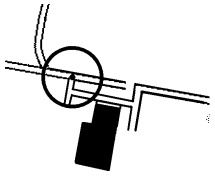
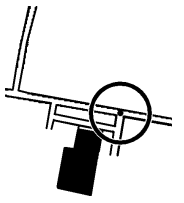
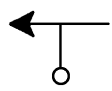
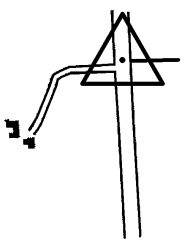
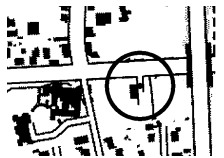
God tur

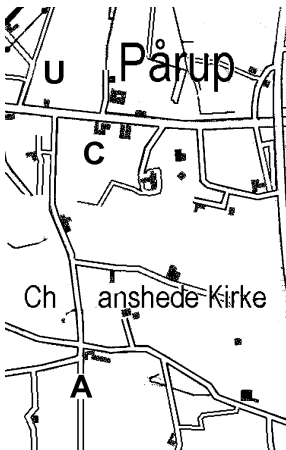
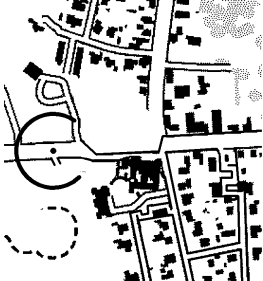
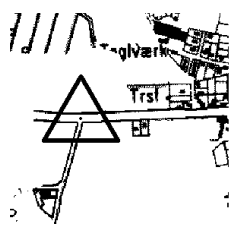
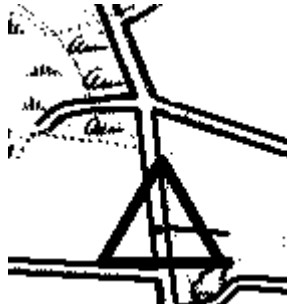
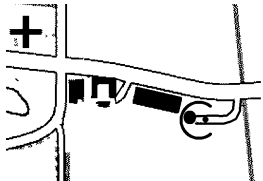
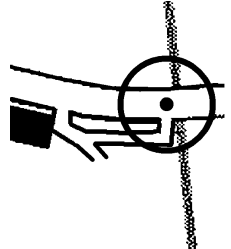
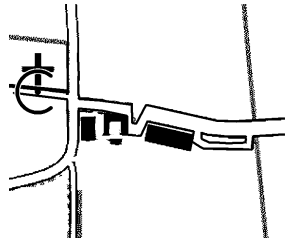
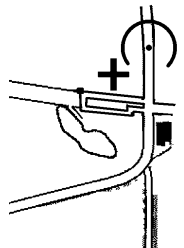
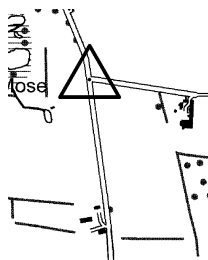

|   |   |  |   |
|---|---|--|---|
| <p>1. Køretid: 6 min. 25km/t</p>  <p>1:50.000</p> | <p>1.</p> <p><b>START:</b><br/>På åben plads.<br/>4 mm<br/>V for C.</p>                                     | <p>2.</p>  <p>1:10.000</p>   | <p>3.</p>  <p>1:5.000</p>    |
|   | <p>4.</p>  <p>1:5.000</p> | <p>5.</p>  <p>100 m</p>      | <p>6.</p>  <p>1:5.000</p>   |
|   | <p>7.</p> <p>Kør<br/>N<br/>155 m.</p>   | <p>8.</p>  <p>1:5.000</p>  | <p>9.</p> <p>Fra N til<br/>vej-T<br/>4 mm<br/>V for M.</p>  |
|   | <p>10.</p>  <p>140 m</p> | <p>11.</p>  <p>1:5.000</p> | <p>12.</p>  <p>1:5.000</p> |

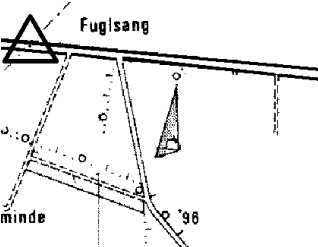
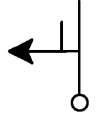
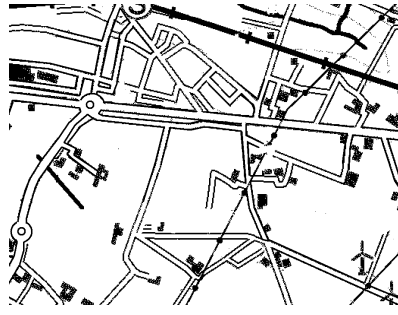
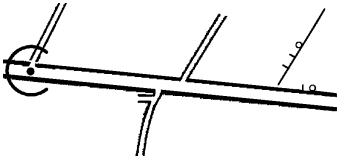
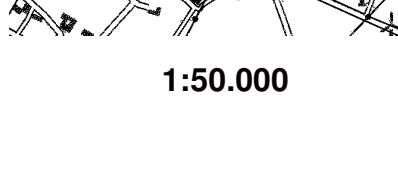
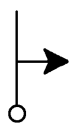

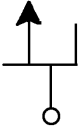
|  |  |  |  |
|--|--|--|--|
| <p>2. Køretid: 6 min. 25km/t</p>  <p>1:50.000</p> | <p>1.</p>  <p>1:2.000</p>     | <p>2.</p> <p>Kør<br/>Ø<br/>145 m.</p>  | <p>3.</p>  <p>1:2.000</p> |
| <p>4.</p>  <p>1:10.000</p>                       | <p>5.</p>  <p>1:20.000</p>  | <p>6.</p> <p>Kør<br/>V<br/>180 m.</p>  |  |
| <p>7.</p>  <p>1:10.000</p>                      | <p>8.</p>  <p>1:10.000</p> | <p>9.</p> <p>Kør<br/>ØSØ<br/>310 m.</p>  | <p>9.</p>  <p>80 m</p>  |
| <p>10.</p>  <p>1:10.000</p>                     | <p>11.</p> <p>Vej-X<br/>4 mm<br/>S for U.</p>  | <p>12.</p> <p>OTK Pårup.</p>  <p>1:10.000</p> |  |

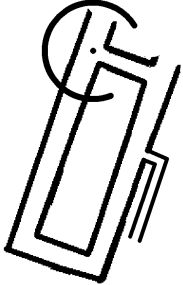
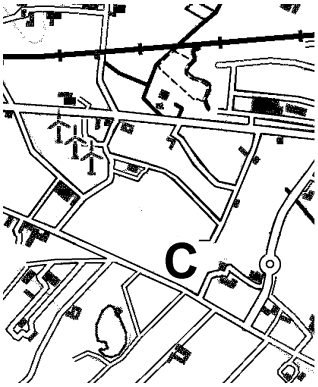
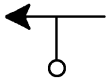
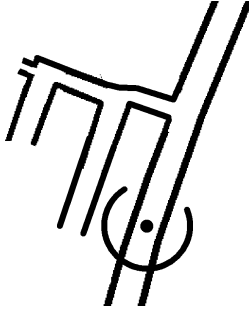
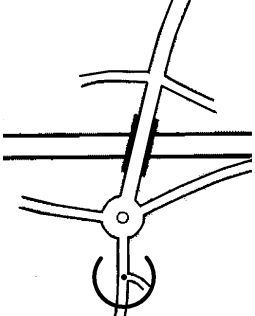
|  |   |   |  |
|--|---|---|--|
| <p>1. Køretid: 20 min. 30km/t</p>  <p>1:50.000</p> | <p>1.</p>  <p>1:10.000</p>     | <p>2.</p>  <p>1:20.000</p>    | <p>3.</p> <p>Vej-T<br/>4 mm<br/>V for C.</p> |
| <p>4.</p> <p>Kør<br/>S<br/>675 m.</p>  | <p>5.</p>  <p>1:10.000</p>   | <p>6.</p> <p>Vej-X<br/>4 mm<br/>N for A.</p>  |  |
| <p>7.</p>  <p>1:10.000</p>                        | <p>8.</p>  <p>1:5.000</p>   | <p>9.</p>  <p>1:10.000</p> |  |
| <p>10.</p>  <p>1:10.000</p>                       | <p>11.</p>  <p>1:20.000</p> | <p>12.</p> <p>Vej-T<br/>4 mm<br/>S for U.</p>   |  |

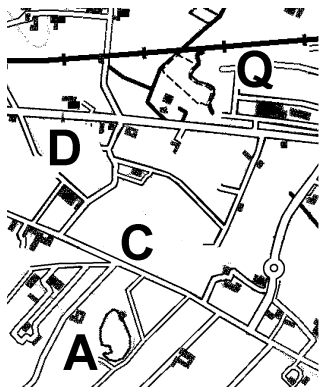
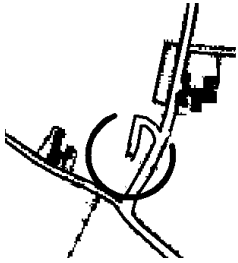
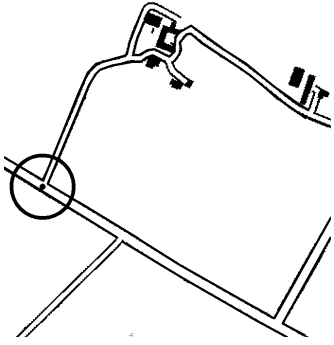

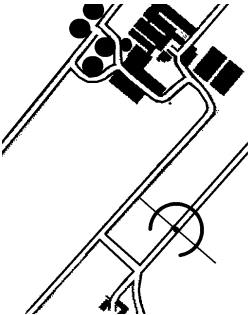
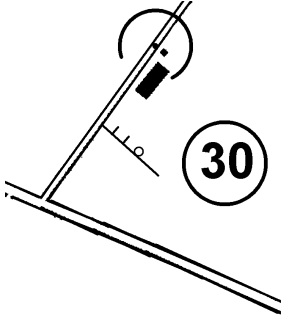
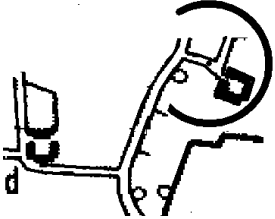
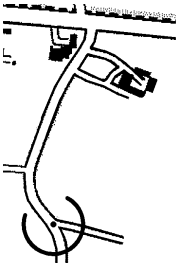

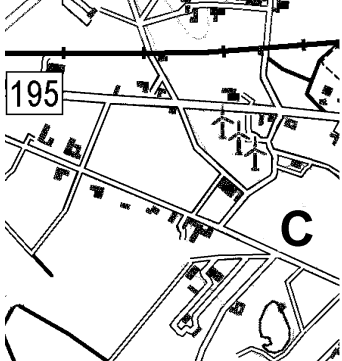
|   |   |  |  |
|---|---|--|--|
| <p>2. Køretid: 5 min. 30km/t</p>  <p>1:50.000</p>   | <p>1.</p>  <p>1:20.000</p> | <p>2.</p> <p>Vej-Y<br/>4 mm<br/>S for C.</p>   | <p>3.</p>  <p>250 m</p> |
| <p>3. Køretid: 6 min. 30km/t</p>  <p>1:50.000</p> | <p>1.</p> <p>Kør<br/>NNV<br/>315 m.</p>   | <p>2.</p>  <p>1:10.000</p> | <p>3.</p> <p>Kør<br/>VNV<br/>730 m.</p>  |
| <p>4.</p>  <p>1:20.000</p>                        | <p>5.</p> <p>Kør<br/>SV<br/>670 m.</p>  | <p>6.</p>  <p>15 m</p>    |  |

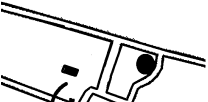
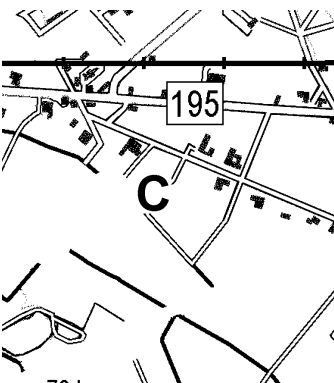
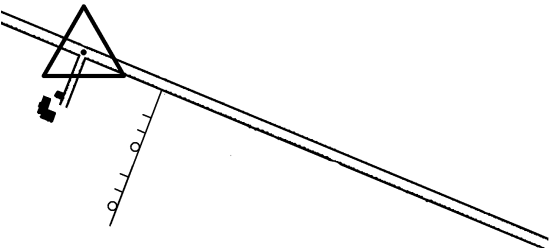
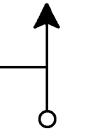
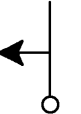
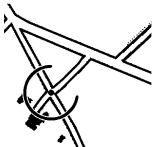

|  |  |  |  |
|--|--|--|--|
| <p>4. Køretid: 2 min. 20km/t</p>   | <p>1.</p>  <p>25 m</p>  | <p>2.</p>  <p>1:2.000</p>  | <p>3.</p>  <p>1:2.000</p>               |
|  <p>1:50.000</p> | <p>4.</p>  <p>110 m</p> | <p>5.</p>  <p>1:2.000</p> | <p>6. OTK Bording</p>  <p>1:10.000</p> |
|  |  |  |  |
|  |  |  |  |

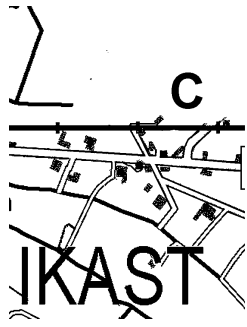
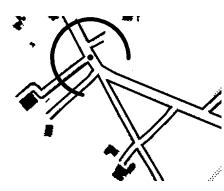
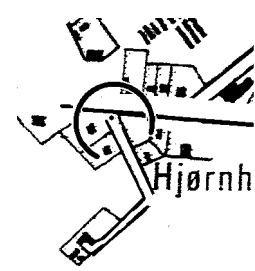
|  |   |  |   |
|--|---|--|---|
| <p>1. Køretid: 11 min. 30km/t</p>  <p>1:50.000</p> | <p>1.</p>  <p>1:10.000</p>     | <p>2.</p> <p>Kør<br/>S<br/>250 m.</p>  | <p>3.</p>  <p>1:10.000</p> |
| <p>4.</p> <p>Vej-T<br/>9 mm<br/>N for A.</p>   | <p>5.</p>  <p>1:10.000</p>   | <p>6.</p>  <p>1:10.000</p> |   |
| <p>7.</p> <p>Vej-T<br/>8 mm<br/>V for C.</p>   | <p>8.</p>  <p>1:10.000</p>  | <p>9.</p> <p>Vej-T<br/>4 mm<br/>Ø for D.</p>   |   |
| <p>10.</p>  <p>1:10.000</p>                       | <p>11.</p>  <p>1:10.000</p> | <p>12.</p> <p>Kør<br/>ØSØ<br/>130 m.</p>   |   |

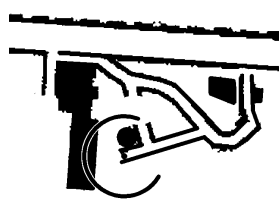
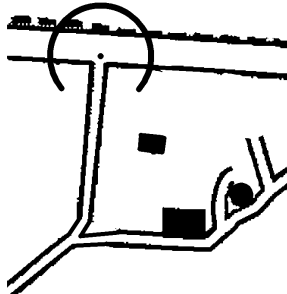
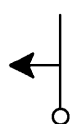
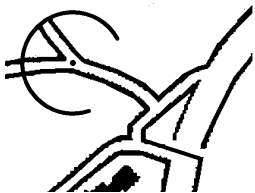
|  |  |   |  |
|--|--|---|--|
| <p>2. Køretid: 4 min. 30km/t</p>  <p>1:50.000</p>    | <p>1.</p>  <p>a v</p> <p>1:10.000</p> | <p>2.</p>  <p>a v</p> <p>1:10.000</p>             | <p>3.</p> <p>Vej-T<br/>8 mm<br/>V for C.</p> |
| <p>3. Køretid: 3 min. 30km/t</p>  <p>1:50.000</p> | <p>1.</p>  <p>1:10.000</p>         | <p>2.</p> <p>Vej-T<br/>4 mm<br/>N for C.</p>  |  |
| <p>3.</p>  <p>365 m</p>                           | <p>4.</p>  <p>23 m</p>             | <p>5.</p> <p>OTK Ravnholt</p>  <p>1:10.000</p> |  |

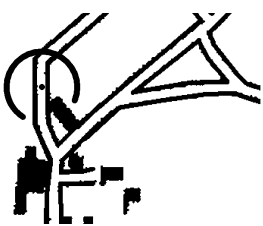

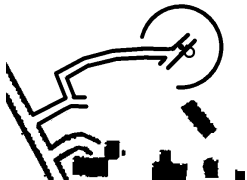
|  |  |  |  |
|--|--|--|--|
| <p>1. Køretid: 5 min. 20km/t</p> <p><b>Kør pænt,<br/>stille og roligt.</b></p> <p><b>Dette gælder<br/>hele etappen.</b></p>  <p><b>IKAST</b></p> <p>1:50.000</p> | <p>1.</p>  <p>1:10.000</p>    | <p>2.</p>  <p>1:10.000</p>   | <p>3.</p>  <p>1:5.000</p> |
| <p>4.</p>  <p>1:5.000</p>  | <p>5.</p>  <p>1:5.000</p>   | <p>6.</p> <p><b>Vej-T<br/>7 mm<br/>S for C.</b></p>  |  |
| <p>7.</p>  <p>70 m</p>  | <p>8.</p>  <p>1:5.000</p>  | <p>9.</p>  <p>1:5.000</p> |  |
| <p>10.</p>  <p>1:5.000</p>  | <p>11.</p>  <p>1:5.000</p> | <p>12.</p> <p><b>Kør<br/>V<br/>70 m.</b></p>   |  |

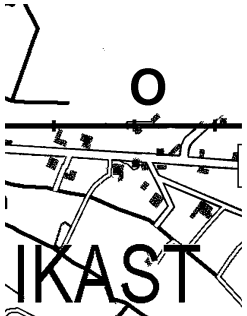
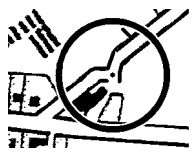
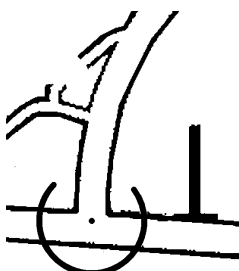
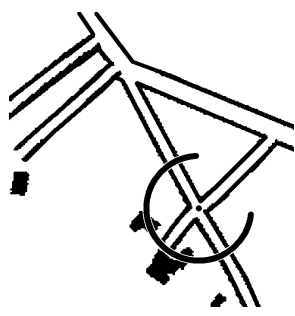
|   |   |   |  |
|---|---|---|--|
| <p>2. Køretid: 3 min. 20km/t</p> <p>Kør pænt,<br/>stille og roligt.</p> <p>Dette gælder<br/>hele etapen.</p>    | <p>1.</p>  <p>1:5.000</p>    | <p>2.</p>  <p>1:5.000</p>                           | <p>3.</p> <p>Kør<br/>ØSØ<br/>61 m.</p>           |
|  <p>IKAST</p> <p>1:50.000</p> | <p>4.</p>  <p>1:10.000</p>  | <p>5.</p>  <p>1:5.000</p>                          | <p>6.</p> <p>Vej-Y<br/>6 mm<br/>S for<br/>O.</p> |
| <p>7.</p> <p>Kør<br/>SSØ<br/>115 m.</p>   | <p>8.</p>  <p>1:5.000</p> | <p>9.</p> <p>I holder<br/>nu ved SK.</p> <p>Kontrolkortet<br/>afleveres og<br/>transportetape<br/>til Nørlundbanen<br/>udleveres.</p> |  |
|   |   |   |  |